

COMPONENTS



Mechanism
Armrest
Base

COMPONENTS

FOUNDATION-1995.06

Mechanism	230
Armrest	252
Base	260

MECHANISM

DHM-1420

New Pron III / 뉴프론 III



Weight Activated Mechanism

- Tilting tension is controlled by user's weight
- Backrest 4 different locking positions
- Backrest&seat synchronizing
- Backrest shock-protection system
- Height adjustment by gas lift
- Main body in die-cast aluminium alloy

- 체중 연동형 톨팅
- 등판 4단 조절 렉킹
- 등판과 좌판 싱크론 기능
- 등판 충격 방지 시스템
- 가스 중심봉 높낮이 조절
- 다이캐스트 알루미늄 합금 본체

floor plan

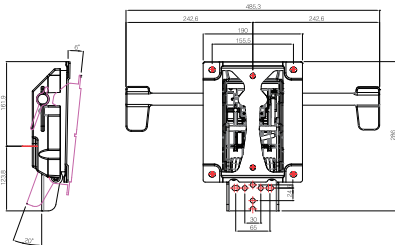

DHM-1430

New Pron III (SLIDE A) / 뉴프론 III (슬라이드 A)



Weight Activated Mechanism

- Tilting tension is controlled by user's weight
- Backrest 4 different locking positions
- Backrest&seat synchronizing
- Backrest shock-protection system
- Adjustable seat depth (only for own seat)
- Height adjustment by gas lift
- Main body in die-cast aluminium alloy

- 체중 연동형 톨팅
- 등판 4단 조절 렉킹
- 등판과 좌판 싱크론 기능
- 등판 충격 방지 시스템
- 좌판 깊이 조절 가능 (전용 좌판 사용 시)
- 가스 중심봉 높낮이 조절
- 다이캐스트 알루미늄 합금 본체

floor plan

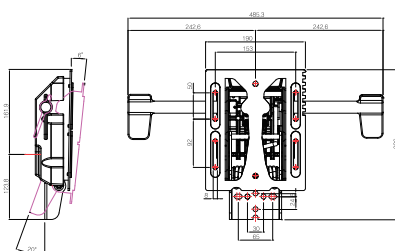

DHM-1435

New Pron III (SLIDE B) / 뉴프론 III (슬라이드 B)



Weight Activated Mechanism

- Tilting tension is controlled by user's weight
- Backrest 4 different locking positions
- Backrest&seat synchronizing
- Backrest shock-protection system
- Adjustable seat depth 5 different locking positions
- Height adjustment by gas lift
- Main body in die-cast aluminium alloy

- 체중 연동형 톨팅
- 등판 4단 조절 렉킹
- 등판과 좌판 싱크론 기능
- 등판 충격 방지 시스템
- 좌판 5단 깊이 조절 가능
- 가스 중심봉 높낮이 조절
- 다이캐스트 알루미늄 합금 본체

floor plan

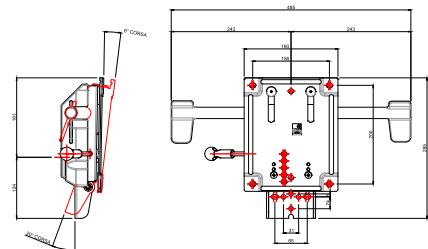

DHM-1400

New Pron II / 뉴프론 II

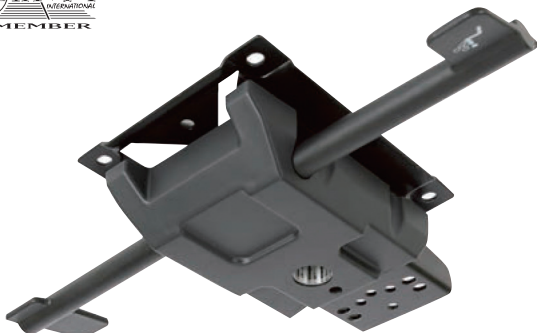

Weight Activated Mechanism

- Tilting tension is controlled by user's weight
- Limit 9 position adjustment
- Backrest&seat synchronizing
- Backrest shock-protection system
- Height adjustment by gas lift
- Main body in die-cast aluminium alloy

- 체중 연동형 틸팅
- 리미트 9단 위치 조절 기능
- 등판과 좌판 싱크론 기능
- 등판 충격 방지 시스템
- 가스 중심봉 높낮이 조절
- 다이캐스트 알루미늄 합금 본체

floor plan

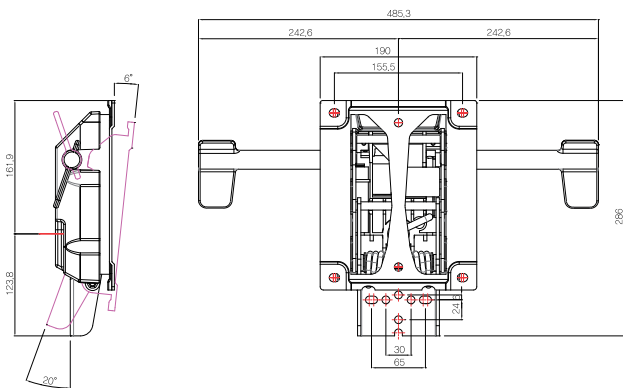

DHM-1410

New Pron II (SLIDE) / 뉴프론 II (슬라이드)

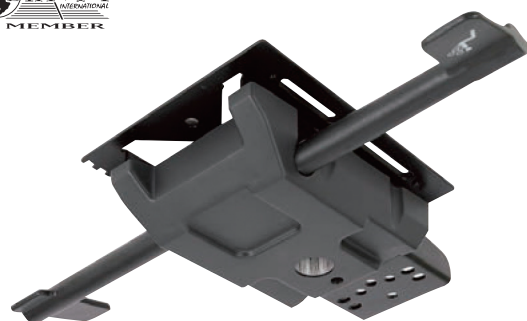

Weight Activated Mechanism

- Tilting tension is controlled by user's weight
- Limit 9 position adjustment
- Backrest&seat synchronizing
- Backrest shock-protection system
- Adjustable seat depth (only for own seat)
- Height adjustment by gas lift
- Main body in die-cast aluminium alloy

- 체중 연동형 틸팅
- 리미트 9단 위치 조절 기능
- 등판과 좌판 싱크론 기능
- 등판 충격 방지 시스템
- 좌판 깊이 조절 기능 (전용 좌판 사용 시)
- 가스 중심봉 높낮이 조절
- 다이캐스트 알루미늄 합금 본체

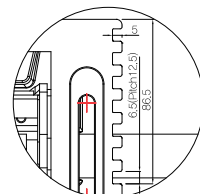

2:1 View

floor plan

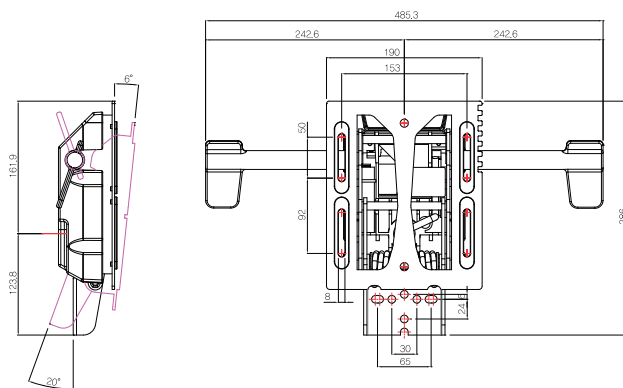

MECHANISM

DHM-1310

EASY II / 이지 II



Weight Activated Mechanism

- Tilting tension is controlled by user's weight
- Limit 4 position adjustment
- Backrest & seat synchronizing
- Height adjustment by gas lift
- Main body in die-cast aluminium alloy
- 체중 연동형 틸팅
- 리미트 4단 위치 조절 기능
- 좌판과 등판 싱크론 기능
- 가스 중심봉 높낮이 조절
- 다이캐스트 알루미늄 합금 본체

floor plan

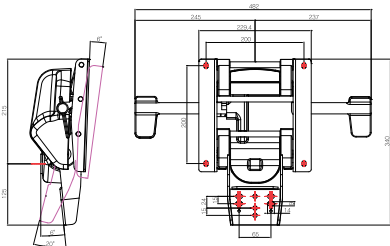

DHM-1320

EASY II (SLIDE A) / 이지 II (슬라이드 A)



Weight Activated Mechanism

- Tilting tension is controlled by user's weight
- Limit 4 position adjustment
- Backrest & seat synchronizing
- Adjustable seat depth (this function is only for own seat)
- Height adjustment by gas lift
- Main body in die-cast aluminium alloy
- 체중 연동형 틸팅
- 리미트 4단 위치 조절 기능
- 좌판과 등판 싱크론 기능
- 좌판 깊이 조절 기능 (전용 좌판 사용 시)
- 가스 중심봉 높낮이 조절
- 다이캐스트 알루미늄 합금 본체

floor plan

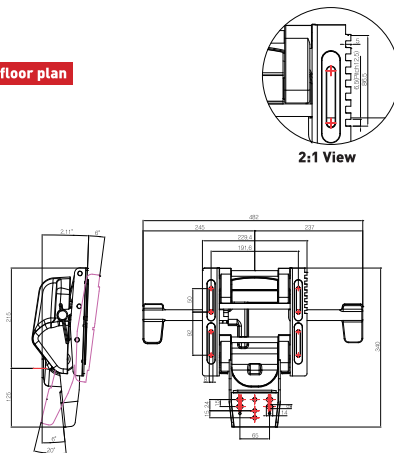

DHM-1325

EASY II (SLIDE B) / 이지 II (슬라이드 B)



Weight Activated Mechanism

- Tilting tension is controlled by user's weight
- Limit 4 position adjustment
- Backrest & seat synchronizing
- Adjustable seat depth 5 different locking positions
- Height adjustment by gas lift
- Main body in die-cast aluminium alloy
- 체중 연동형 틸팅
- 리미트 4단 위치 조절 기능
- 좌판과 등판 싱크론 기능
- 좌판 5단 깊이 조절 기능
- 가스 중심봉 높낮이 조절
- 다이캐스트 알루미늄 합금 본체

floor plan

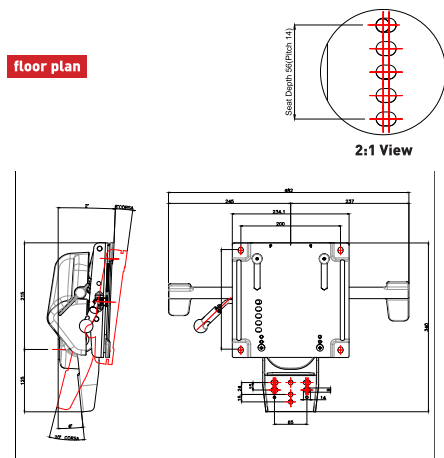

DHM-300

Pron / 프론



- Backrest 5 different locking positions
- Backrest & seat synchronizing
- Backrest shock-protection system
- Backrest tilting tension adjustment
- Height adjustment by gas lift
- Main body in die-cast aluminium alloy

- 등판 5단 조절 렉킹
- 등판과 좌판 싱크론 기능
- 등판 충격 방지 시스템
- 등판 틸팅 강도 조절
- 가스 중심봉 높낮이 조절
- 다이캐스트 알루미늄 합금 본체

DHM-350

New Pron / 뉴프론



- Backrest 4 different locking positions
- Backrest & seat synchronizing
- Tilting tension adjustment-lever is a side
- Backrest shock-protection system
- Backrest tilting tension adjustment
- Height adjustment by gas lift

- 등판 4단 조절 렉킹
- 등판과 좌판 싱크론 기능
- 틸팅 조절 손잡이 옆면에 위치
- 등판 충격 방지 시스템
- 등판 틸팅 강도 조절
- 가스 중심봉 높낮이 조절

floor plan

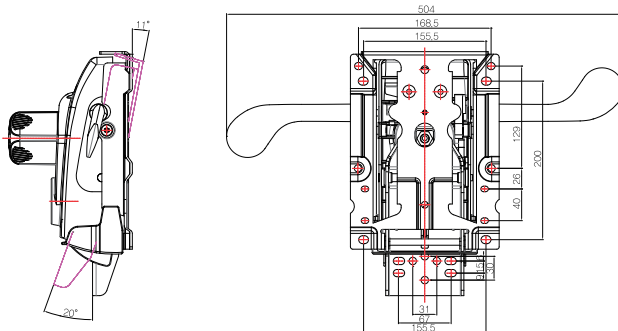

floor plan

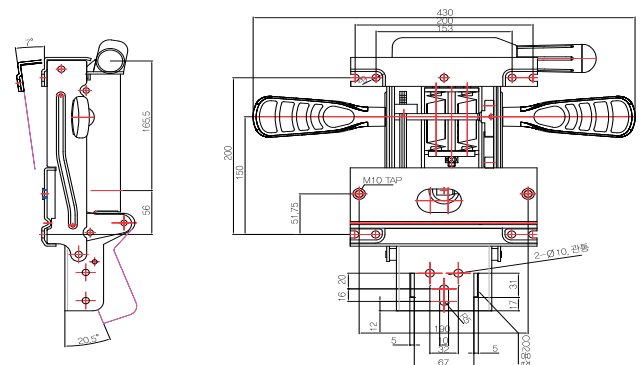

MECHANISM

DHM-800

Dynamic I / 다이내믹 I

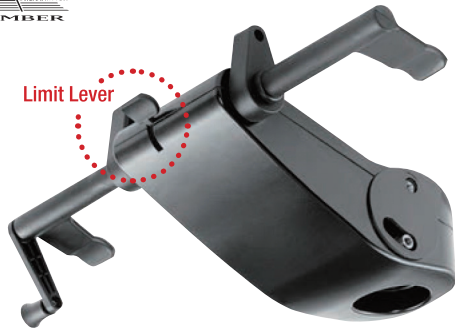

- Backrest 4 different locking positions
- Limit 3 position adjustment
- Backrest, seat and back-frame synchronizing
- Tilting adjustment lever is on the side
- Backrest shock-protection system
- Backrest tilting tension adjustment
- Height adjustment by gas lift
- Main body in die-cast aluminium alloy

- 등판 4단 조절 렉킹
- 리미트 3단 위치 조절 기능
- 등판과 좌판, 등후레임의 싱크론 기능
- 틸팅 조절 손잡이 옆면에 위치
- 등판 충격 방지 시스템
- 등판 틸팅 강도 조절
- 가스 중심봉 높낮이 조절
- 다이캐스트 알루미늄 합금 본체

floor plan

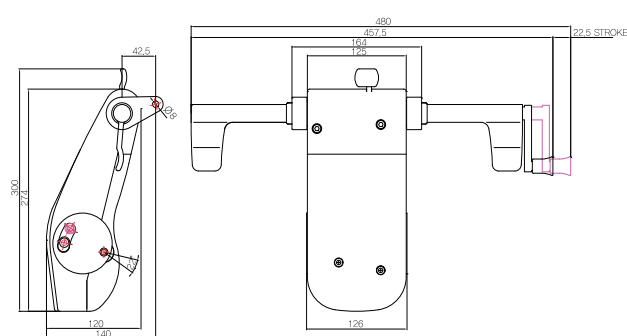

DHM-810

Dynamic II / 다이내믹 II

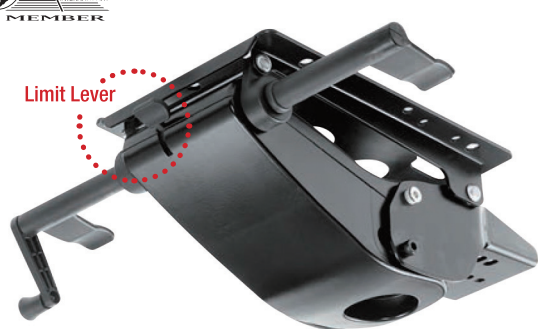

- Backrest 4 different locking positions
- Limit 3 position adjustment
- Backrest, seat synchronizing
- Tilting adjustment lever is on the side
- Backrest shock-protection system
- Backrest tilting tension adjustment
- Height adjustment by gas lift
- Main body in die-cast aluminium alloy

- 등판 4단 조절 렉킹
- 리미트 3단 위치 조절 기능
- 등판과 좌판 싱크론 기능
- 틸팅 조절 손잡이 옆면에 위치
- 등판 충격 방지 시스템
- 등판 틸팅 강도 조절
- 가스 중심봉 높낮이 조절
- 다이캐스트 알루미늄 합금 본체

floor plan

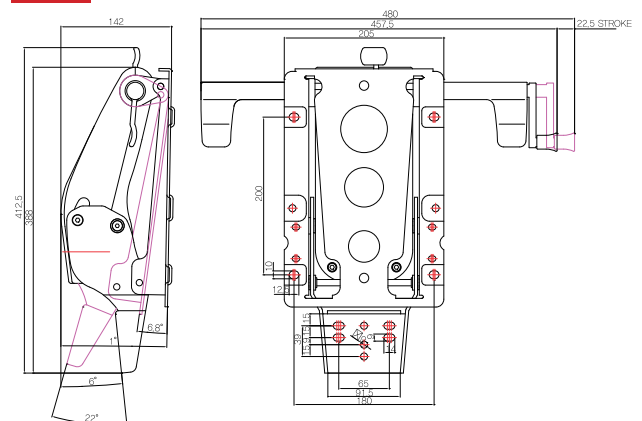

DHM-820

Limit Dynamic I / 리미트 다이내믹 I



- Limit 4 position adjustment
 - Backrest, seat and back-frame synchronizing
 - Tilting adjustment lever is on the side
 - Backrest tilting tension adjustment
 - Height adjustment by gas lift
 - Main body in die-cast aluminium alloy
- 리미트 4단 위치 조절 기능
 - 등판과 좌판, 등후레임의 싱크론 기능
 - 틸팅 조절 손잡이 옆면에 위치
 - 등판 틸팅 강도 조절
 - 가스 중심봉 높낮이 조절
 - 다이캐스트 알루미늄 합금 본체

DHM-830

Limit Dynamic II / 리미트 다이내믹 II



- Limit 4 position adjustment
 - Backrest, seat synchronizing
 - Tilting adjustment lever is on the side
 - Backrest tilting tension adjustment
 - Height adjustment by gas lift
 - Main body in die-cast aluminium alloy
- 리미트 4단 위치 조절 기능
 - 등판과 좌판 싱크론 기능
 - 틸팅 조절 손잡이 옆면에 위치
 - 등판 틸팅 강도 조절
 - 가스 중심봉 높낮이 조절
 - 다이캐스트 알루미늄 합금 본체

floor plan

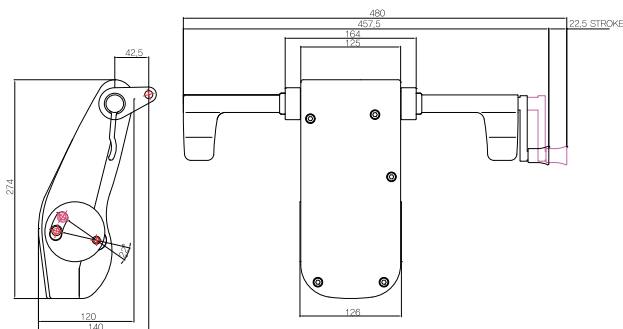

floor plan

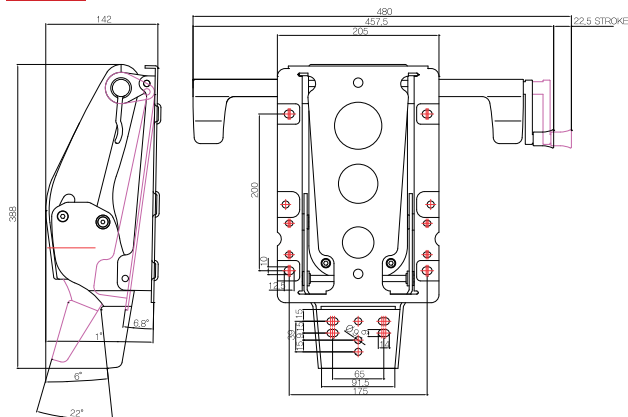

MECHANISM

DHM-1100

REX I / 렉스 I



- Backrest 4 different locking positions
- Limit 3 position adjustment
- Seat slide synchronized tilting function by its rail on mechanism
- Backrest, seat and back-frame synchronizing
- Backrest tilting tension adjustment
- Backrest shock-protection system
- Height adjustment by gas lift
- Main body in die-cast aluminium alloy

- 등판 4단 조절 렉킹
- 리미트 3단 위치 조절 기능
- 좌판 슬라이드 싱크로나이즈 틸팅 기능
- 등판, 좌판, 후레임의 싱크론 기능
- 등판 틸팅 강도 조절
- 등판 충격 방지 시스템
- 가스 중심봉 높낮이 조절
- 다이캐스트 알루미늄 합금 본체

floor plan

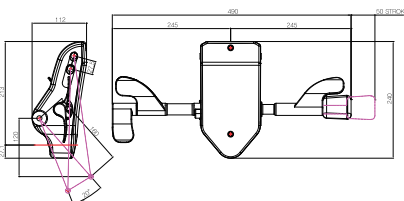

DHM-1200

REX II / 렉스 II



- Backrest 4 different locking positions
- Limit 3 position adjustment
- Seat slide synchronized tilting function by its rail on mechanism
- Backrest&seat synchronizing
- Backrest tilting tension adjustment
- Backrest shock-protection system
- Height adjustment by gas lift
- Main body in die-cast aluminium alloy

- 등판 4단 조절 렉킹
- 리미트 3단 위치 조절 기능
- 좌판 슬라이드 싱크로나이즈 틸팅 기능
- 등판과 좌판 싱크론 기능
- 등판 틸팅 강도 조절
- 등판 충격 방지 시스템
- 가스 중심봉 높낮이 조절
- 다이캐스트 알루미늄 합금 본체

floor plan

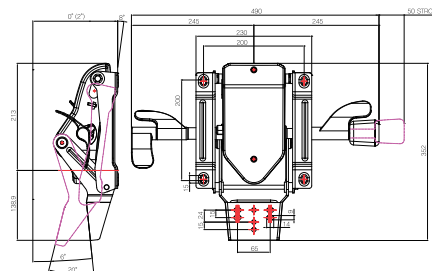

DHM-1210

REX II (SLIDE A) / 렉스 II (슬라이드 A)



- Backrest 4 different locking positions
- Limit 3 position adjustment
- Seat slide synchronized tilting function by its rail on mechanism
- Backrest&seat synchronizing
- Backrest tilting tension adjustment
- Backrest shock-protection system
- Adjustable seat depth (this function is only for own seat)
- Height adjustment by gas lift
- Main body in die-cast aluminium alloy

- 등판 4단 조절 렉킹
- 리미트 3단 위치 조절 기능
- 좌판 슬라이드 싱크로나이즈 틸팅 기능
- 등판과 좌판 싱크론 기능
- 등판 틸팅 강도 조절
- 등판 충격 방지 시스템
- 좌판 깊이 조절 기능 (전용 좌판 사용 시)
- 가스 중심봉 높낮이 조절
- 다이캐스트 알루미늄 합금 본체

floor plan

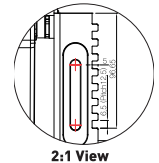
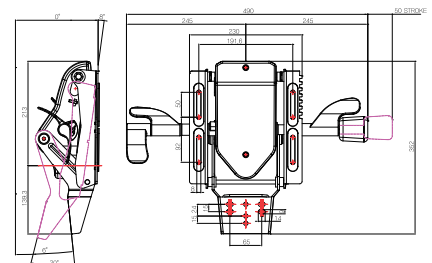

DHM-1110

NEW REX I / 뉴 렉스 I



- Backrest 4 different locking positions
- Limit 7 position adjustment
- Seat slide synchronized tilting function by its rail on mechanism
- Backrest, seat and back-frame synchronizing
- Backrest tilting tension adjustment
- Backrest shock-protection system
- Height adjustment by gas lift
- Main body in die-cast aluminium alloy

- 등판 4단 조절 렉킹
- 리미트 7단 위치 조절 기능
- 좌판 슬라이드 싱크로나이즈 틸팅 기능
- 등판, 좌판, 후레임의 싱크론 기능
- 등판 틸팅 강도 조절
- 등판 충격 방지 시스템
- 가스 중심봉 높낮이 조절
- 다이캐스트 알루미늄 합금 본체

floor plan

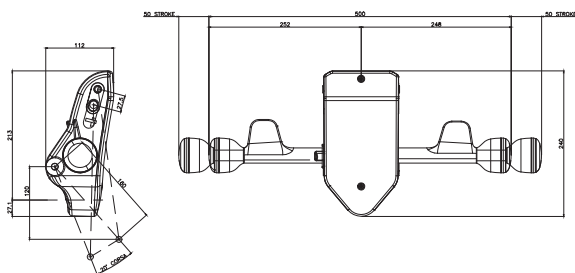

DHM-1220

NEW REX II / 뉴 렉스 II



- Backrest 4 different locking positions
- Limit 7 position adjustment
- Seat slide synchronized tilting function by its rail on mechanism
- Backrest&seat synchronizing
- Backrest tilting tension adjustment
- Backrest shock-protection system
- Height adjustment by gas lift
- Main body in die-cast aluminium alloy

- 등판 4단 조절 렉킹
- 리미트 7단 위치 조절 기능
- 좌판 슬라이드 싱크로나이즈 틸팅 기능
- 등판과 좌판 싱크론 기능
- 등판 틸팅 강도 조절
- 등판 충격 방지 시스템
- 가스 중심봉 높낮이 조절
- 다이캐스트 알루미늄 합금 본체

floor plan

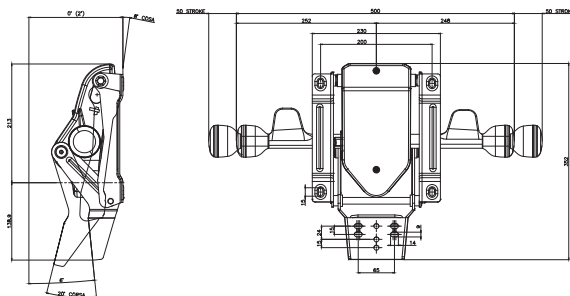

MECHANISM

DHM-1215

REX II (SLIDE B) / 렉스 II (슬라이드 B)



- Backrest 4 different locking positions
- Limit 3 position adjustment
- Seat slide synchronized tilting function by its rail on mechanism
- Backrest&seat synchronizing
- Backrest tilting tension adjustment
- Backrest shock-protection system
- Adjustable seat depth 5 different locking positions
- Height adjustment by gas lift
- Main body in die-cast aluminium alloy

- 등판 4단 조절 렉킹
- 리미트 3단 위치 조절 기능
- 좌판 슬라이드 싱크로나이즈 틸팅 기능
- 등판과 좌판 싱크론 기능
- 등판 틸팅 강도 조절
- 등판 충격 방지 시스템
- 좌판 5단 깊이 조절 기능
- 가스 중심봉 높낮이 조절
- 다이캐스트 알루미늄 합금 본체

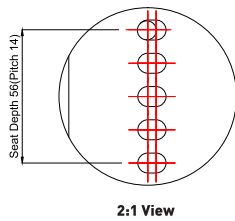

2:1 View

floor plan

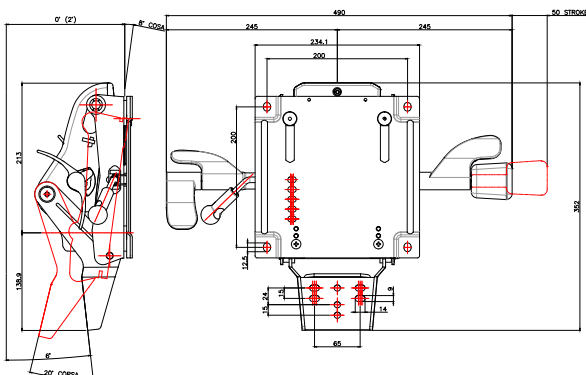

DHM-230

Synchron II (SLIDE) / 싱크론 II (슬라이드)



- Backrest 4 different locking positions
- Limit 3 position adjustment
- Backrest&seat synchronizing
- Backrest shock-protection system
- Backrest tilting tension adjustment
- Adjustable seat depth (this function is only for own seat)
- Height adjustment by gas lift
- Main body in die-cast aluminium alloy

- 등판 4단 조절 렉킹
- 리미트 3단 위치 조절 기능
- 등판과 좌판 싱크론 기능
- 등판 충격 방지 시스템
- 등판 틸팅 강도 조절
- 좌판 깊이 조절 기능 (전용 좌판 사용 시)
- 가스 중심봉 높낮이 조절
- 다이캐스트 알루미늄 합금 본체

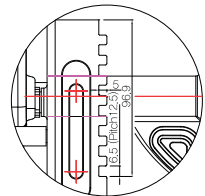

2:1 View

floor plan

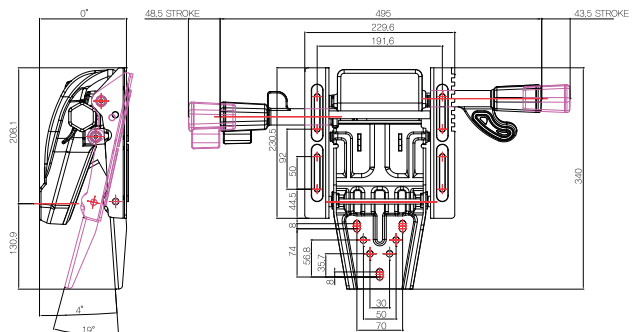

DHM-100

Multi Block I / 멀티블락 I



- Backrest 6 different locking positions
- Backrest shock-protection system
- Backrest tilting tension adjustment
- Height adjustment by gas lift
- Main body in die-cast aluminium alloy

- 등판 6단 조절 렉킹
- 등판 충격 방지 시스템
- 등판 틸팅 강도 조절
- 가스 중심봉 높낮이 조절
- 다이캐스트 알루미늄 합금 본체

DHM-200

Synchron I / 싱크론 I



- Backrest 5 different locking positions
- Backrest & seat synchronizing
- Backrest shock-protection system
- Backrest tilting tension adjustment
- Height adjustment by gas lift
- Main body in die-cast aluminium alloy

- 등판 5단 조절 렉킹
- 좌판과 등판 싱크론 기능
- 등판 충격 방지 시스템
- 등판 틸팅 강도 조절
- 가스 중심봉 높낮이 조절
- 다이캐스트 알루미늄 합금 본체

floor plan

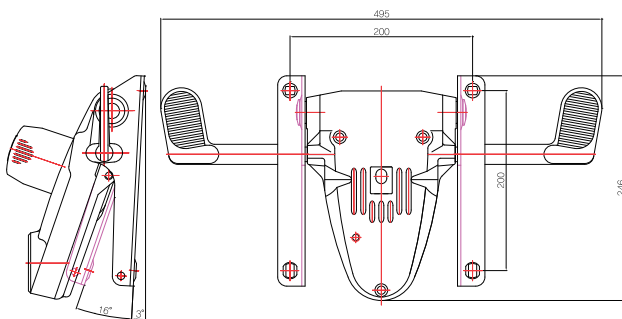

floor plan

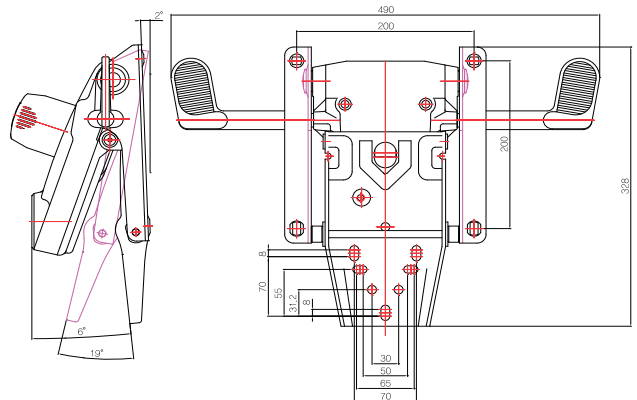

MECHANISM

DHM-110

Multi Block II / 멀티 II



- Backrest 4 different locking positions
- Limit 3 position adjustment
- Backrest shock-protection system
- Backrest tilting tension adjustment
- Height adjustment by gas lift
- Main body in die-cast aluminium alloy

- 등판 4단 조절 렉킹
- 리미트 3단 위치 조절 기능
- 등판 충격 방지 시스템
- 등판 틸팅 강도 조절
- 가스 중심봉 높낮이 조절
- 다이캐스트 알루미늄 합금 본체

floor plan

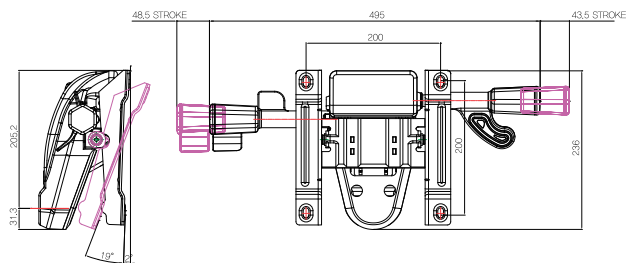

DHM-210

Synchron II / 싱크론 II

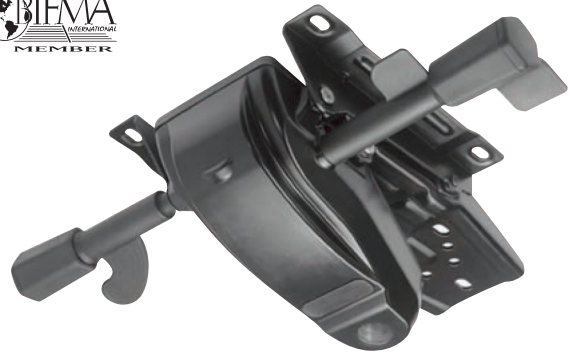

- Backrest 4 different locking positions
- Limit 3 position adjustment
- Backrest & seat synchronizing
- Backrest shock-protection system
- Backrest tilting tension adjustment
- Height adjustment by gas lift
- Main body in die-cast aluminium alloy

- 등판 4단 조절 렉킹
- 리미트 3단 위치 조절 기능
- 좌판과 등판 싱크론 기능
- 등판 충격 방지 시스템
- 등판 틸팅 강도 조절
- 가스 중심봉 높낮이 조절
- 다이캐스트 알루미늄 합금 본체

floor plan

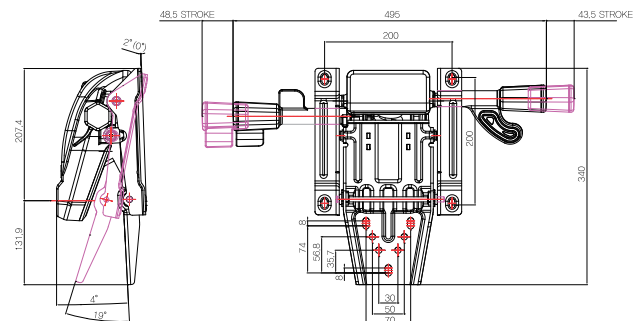

MECHANISM

DHM-500

Limit Multi / 리미트 멀티

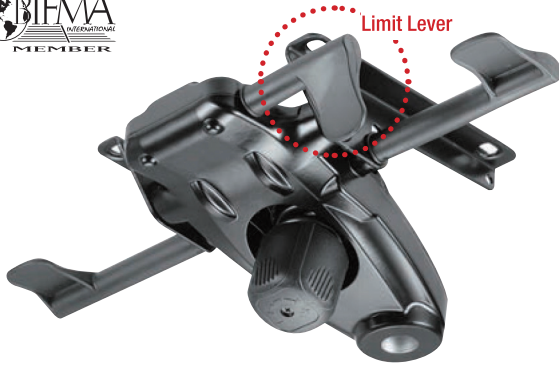

- Backrest 6 different locking positions
- Limit 5 position adjustment
- Backrest shock-protection system
- Backrest tilting tension adjustment
- Height adjustment by gas lift
- Main body in die-cast aluminium alloy

- 등판 6단 조절 렉킹
- 리미트 5단 위치 조절 기능
- 등판 충격 방지 시스템
- 등판 틸팅 강도 조절
- 가스 중심봉 높낮이 조절
- 다이캐스트 알루미늄 합금 본체

floor plan

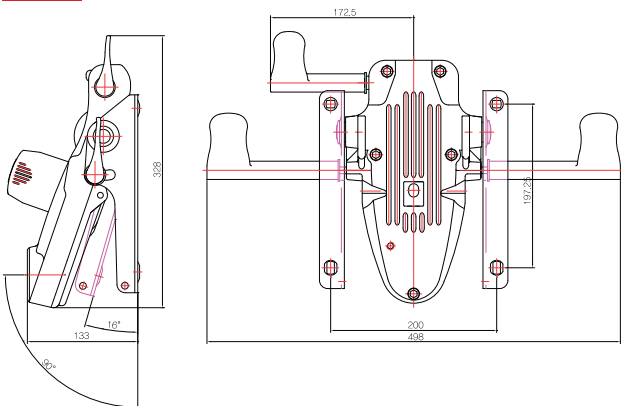

DHM-550

Limit Synchron / 리미트 싱크론

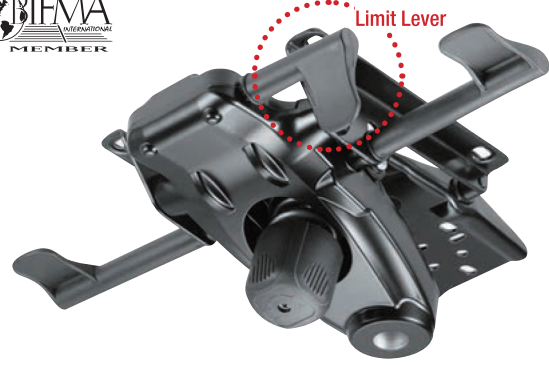

- Backrest 5 different locking positions
- Limit 4 position adjustment
- Backrest & seat synchronizing
- Backrest shock-protection system
- Backrest tilting tension adjustment
- Height adjustment by gas lift
- Main body in die-cast aluminium alloy

- 등판 5단 조절 렉킹
- 리미트 4단 위치 조절 기능
- 등판과 좌판 싱크론 기능
- 등판 충격 방지 시스템
- 등판 틸팅 강도 조절
- 가스 중심봉 높낮이 조절
- 다이캐스트 알루미늄 합금 본체

floor plan

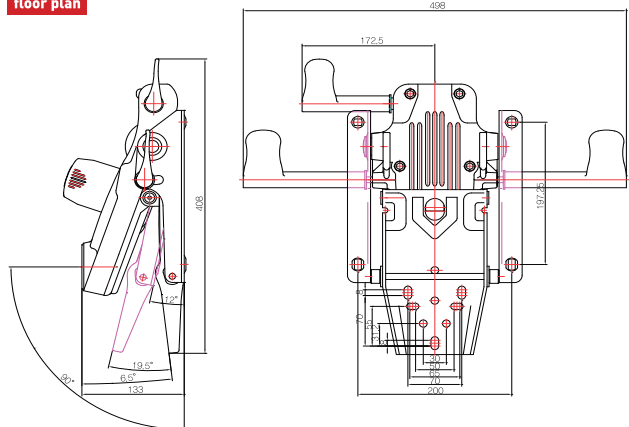

DHM-400

Ribero I / 리베로 I



- Backrest 4 different locking positions
- Backrest & seat synchronizing
- Backrest shock-protection system
- Backrest tilting tension adjustment
- Height adjustment by gas lift
- Main body in die-cast aluminium alloy

- 등판 4단 조절 렉킹
- 등판과 좌판 싱크론 기능
- 등판 충격 방지 시스템
- 등판 틸팅 강도 조절
- 가스 중심봉 높낮이 조절
- 다이캐스트 알루미늄 합금 본체

DHM-450

Ribero II / 리베로 II



- Backrest 4 different locking positions
- Backrest & seat synchronizing
- Seat tilts forward in 5 degrees
- Backrest shock-protection system
- Backrest tilting tension adjustment
- Height adjustment by gas lift
- Main body in die-cast aluminium alloy

- 등판 4단 조절 렉킹
- 등판과 좌판 싱크론 기능
- 좌판 전방 5도 틸팅 기능
- 등판 충격 방지 시스템
- 등판 틸팅 강도 조절
- 가스 중심봉 높낮이 조절
- 다이캐스트 알루미늄 합금 본체

floor plan

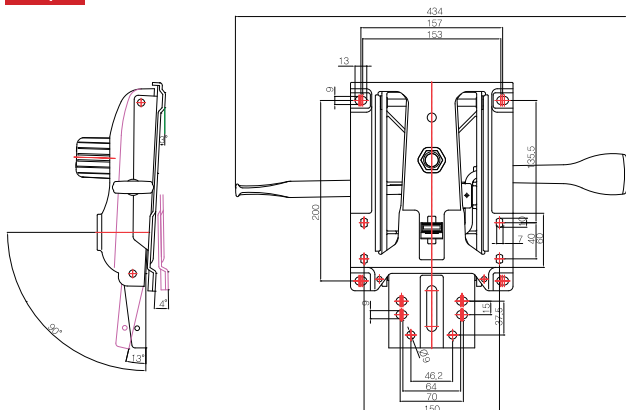

floor plan

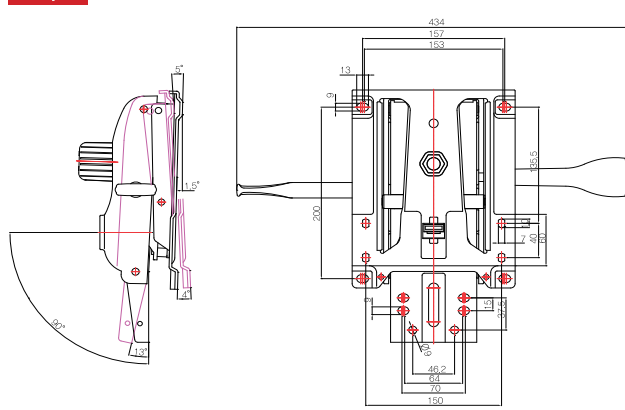

MECHANISM

DHM-700

Kobra Locking / 코브라 락킹

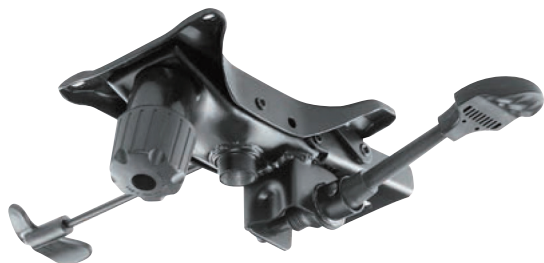

- Backrest positioned at any position (free position locking)
- Backrest & seat synchronizing
- Backrest tilting tension adjustment
- Height adjustment by gas lift
- 등판 무한 위치 고정기능 (자유 위치 락킹)
- 등판과 좌판 싱크론 기능
- 등판 틸팅 강도 조절
- 가스 중심봉 높낮이 조절

floor plan

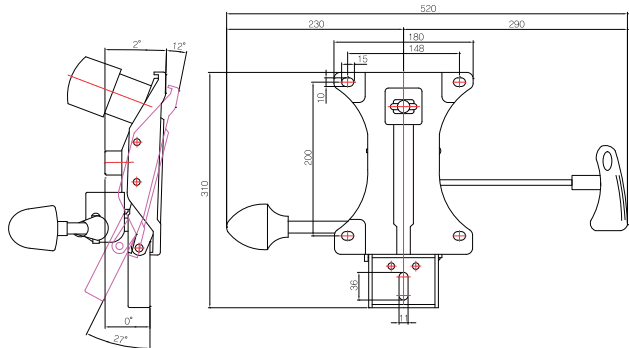

DHM-600

Air Locking I / 에어락킹 I (실린더형)



- Backrest & seat synchronizing
- Backrest 1 different locking positions
- Backrest tilting tension adjustment
- Height adjustment by gas lift
- 등판과 좌판 싱크론 기능
- 등판 1단 조절 락킹
- 등판 틸팅 강도 조절
- 가스 중심봉 높낮이 조절

floor plan

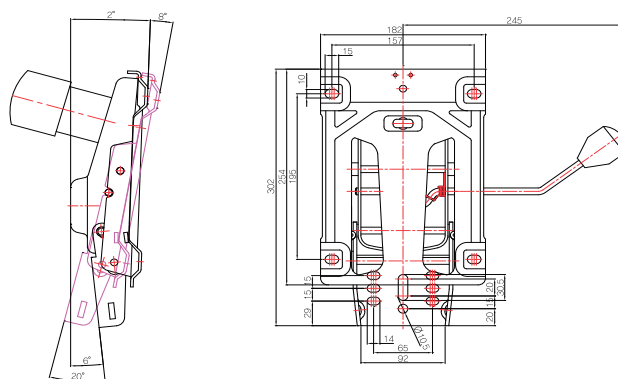

MECHANISM

DHM-001

Sky / 스카이 후레임실린더



- Stopping lever can be equipped
- Height adjustment by gas lift
- 스톱바 가능 (수동스톱바, 자동스톱바)
- 가스 중심봉 높낮이 조절

DHM-002

Toto / 토토 후레임실린더



- Height adjustment by gas lift
- 가스 중심봉 높낮이 조절

DHM-003

Ariana / 아리아나 후레임실린더



- Stopping lever can be equipped
- Height adjustment by gas lift
- 스톱바 가능 (수동스톱바, 자동스톱바)
- 가스 중심봉 높낮이 조절

DHM-004

Delta / 델타 후레임실린더



- Height adjustment by gas lift
- 가스 중심봉 높낮이 조절

DHM-005

Bigstar / 빅스타 후레임실린더



- Height adjustment by gas lift
- 가스 중심봉 높낮이 조절

DHM-006

Magic / 매직 후레임실린더



- Height adjustment by gas lift
- 가스 중심봉 높낮이 조절

DHM-007

Active / 액티브 후레임실린더



- Height adjustment by gas lift
- 가스 중심봉 높낮이 조절

DHM-008

Mas / 마스 후레임실린더



- Stopping lever can be equipped
- Height adjustment by gas lift
- 스톱바 가능 (수동스톱바, 자동스톱바)
- 가스 중심봉 높낮이 조절

MECHANISM

DHM-009

Capri / 카프리 후레임실린더



- Stopping lever can be equipped
- Height adjustment by gas lift
- 스톱바 가능 (수동스톱바, 자동스톱바)
- 가스 중심봉 높낮이 조절

DHM-010

Health Mesh (65) / 헬스메쉬 (65) 수동스톱



- Manual stopping
- Height adjustment by gas lift
- 수동스톱바 가능
- 가스 중심봉 높낮이 조절

DHM-011

Health Mesh (65) / 헬스메쉬 (65) 자동스톱



- Automatic stopping
- Height adjustment by gas lift
- 자동스톱바 가능
- 가스 중심봉 높낮이 조절

DHM-012

Health Mesh (90) / 헬스메쉬 (90) 수동스톱



- Manual stopping
- Height adjustment by gas lift
- 수동스톱바 가능
- 가스 중심봉 높낮이 조절

DHM-013

Health Mesh (90) / 헬스메쉬 (90) 자동스톱



- Automatic stopping
- Height adjustment by gas lift
- 자동스톱바 가능
- 가스 중심봉 높낮이 조절

DHM-014

Kicker TinTin / 키커틴틴



- Height adjustment by gas lift
- 가스 중심봉 높낮이 조절

DHM-015

Steel Plate Locking / 철판락킹



- Height adjustment by gas lift
- 가스 중심봉 높낮이 조절

DHM-017

Butterfly Locking | / 나비락킹 |



- Main body in die-cast aluminium alloy
- Height adjustment by gas lift
- 다이캐스트 알루미늄 합금 본체
- 가스 중심봉 높낮이 조절

MECHANISM

DHM-019

New Kobra Locking / 코브라 락킹 (New)

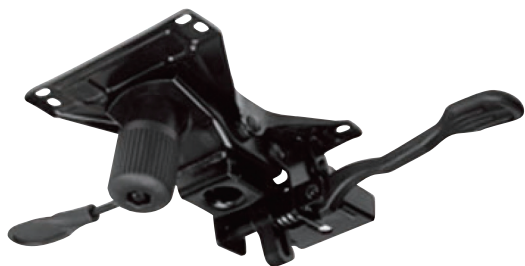

- Backrest positioned at any position (free position locking)
- Backrest & seat synchronizing
- Backrest tilting tension adjustment
- Height adjustment by gas lift
- 등판 무한 위치 고정 기능 (자유 위치 락킹)
- 등판과 좌판 싱크론 기능
- 등판 틸팅 강도 조절
- 가스 중심봉 높낮이 조절

DHM-020

Jodal Locking / 조달 락킹



- Stopping lever can be equipped
- Height adjustment by gas lift
- 스톱바 가능 (수동스톱바, 자동스톱바)
- 가스 중심봉 높낮이 조절

DHM-021

Fromy Locking / 포미락킹



- Height adjustment by gas lift
- 가스 중심봉 높낮이 조절

DHM-022

Cello / 첼로



- Height adjustment by gas lift
- 가스 중심봉 높낮이 조절

DHM-025

D2-200 Locking / D2-200 렉킹



- Stopping lever can be equipped
- Height adjustment by gas lift
- 스톱바 가능 (수동스톱바, 자동스톱바)
- 가스 중심봉 높낮이 조절

DHM-030

Injection Locking / 사출렉킹



- Height adjustment by gas lift
- 가스 중심봉 높낮이 조절

DHM-035

Injection Folding Locking / 사출 폴딩 렉킹



- Height adjustment by gas lift
- 가스 중심봉 높낮이 조절

DHM-040

DM1 Injection Locking / DM1 사출 렉킹



- Height adjustment by gas lift
- 가스 중심봉 높낮이 조절

ARMREST

DHA-930

Dynamic I / 다이내믹 I



Black



White

- Height adjustment
- Armrest pad slide forward and backward
- Armrest pad is rotatable

- 높낮이 조절 가능
- 패드 전 · 후진
- 패드 회전

DHA-940

Dynamic II / 다이내믹 II



Black



White

- Height adjustment
- Armrest pad slide forward and backward
- Armrest pad is rotatable

- 높낮이 조절 가능
- 패드 전 · 후진
- 패드 회전

DHA-700

T,A 3D / 티.에이 3D



Black



White

- Height adjustment
- Armrest pad slide forward and backward
- Armrest pad is rotatable

- 높낮이 조절 가능
- 패드 전·후진
- 패드 회전

DHA-710

T,A 4D / 티.에이 4D



Black



White

- Height adjustment
- Armrest pad slide forward and backward
- Armrest pad move it left or right
- Armrest pad is rotatable

- 높낮이 조절 가능
- 패드 전·후진
- 패드 좌·우 이동
- 패드 회전

ARMREST

DHA-250

Aries I / 에리스 I



- Height adjustment
- 높낮이 조절 가능

DHA-260

Aries II / 에리스 II



Black



White

- Height adjustment
- Armrest pad slide forward and backward
- Armrest pad is rotatable
- 높낮이 조절 가능
- 패드 전 · 후진
- 패드 회전

DHA-280

Active 3D / 액티브 3D



Black



White

- Height adjustment
- Armrest pad slide forward and backward
- Armrest pad is rotatable

- 높낮이 조절 가능
- 패드 전·후진
- 패드 회전

DHA-290

Active 4D / 액티브 4D



Black



White

- Height adjustment
- Armrest pad slide forward and backward
- Armrest pad move it left or right
- Armrest pad is rotatable

- 높낮이 조절 가능
- 패드 전·후진
- 패드 좌·우 이동
- 패드 회전

ARMREST

DHA-600

Lepus I / 레푸스 I



- Height adjustment
- 높낮이 조절 가능

DHA-610

Lepus II / 레푸스 II



- Height adjustment
- Armrest pad slide forward and backward
- Armrest pad is rotatable

- 높낮이 조절 가능
- 패드 전·후진
- 패드 회전

DHA-620

Lepus III / 레푸스 III



- Height adjustment
- 높낮이 조절 가능

DHA-300

Ribero / 리베로



- Height adjustment and armrest turns
- 높낮이 조절 가능 및 회전

DHA-270

Vela / 벨라



Black



White

- Fixed type
- 고정형

DHA-100

Orion / 오리온



- Height adjustment and armrest turns
- 높낮이 조절 가능 및 회전

DHC-001

Coat Hanger / 옷걸이



ARMREST

DHA-240

Ara / 아라



Black



White

- Fixed type
- 고정형

- Fixed type
- 고정형

DHA-220

Libra / 리브라



Black



White

- Fixed type
- 고정형

- Fixed type
- 고정형

DHA-210

Zeon / 제온



- Fixed type
- 고정형

DHA-230

Atrix / 아트릭스



- Fixed type
- 고정형

DHA-019

Ursa / 우르사



- Fixed type
- 고정형

BASE

DHB-100

Steel Base II / 스틸 베이스 II



Ø720

DHB-110

Steel Base III / 스틸 베이스 III



Ø600 | Ø660 | Ø720

DHB-120

Steel Base IV / 스틸 베이스 IV



Ø580

DHB-300

Aluminum Base I / 알루미늄 베이스 I



Ø720

DHB-310

Aluminum Base II / 알루미늄 베이스 II



Ø680

DHB-320

Aluminum Base III / 알루미늄 베이스 III



Ø700

DHB-330

Aluminum Base IV / 알루미늄 베이스 IV



Ø700

DHB-200

Injection Base I / 사출 베이스 I



Ø630 | Ø680
Black



Ø630 | Ø680
White

DHB-210

Injection Base II / 사출 베이스 II



Ø690
Black



Ø690
White

CERTIFICATES

Certificates 인증서

BIFMA

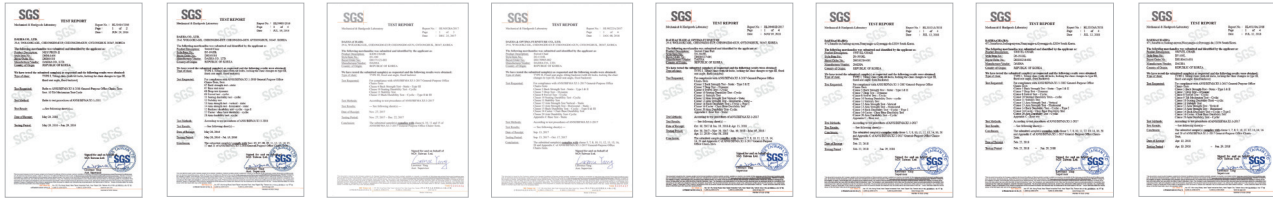

디자인



특허

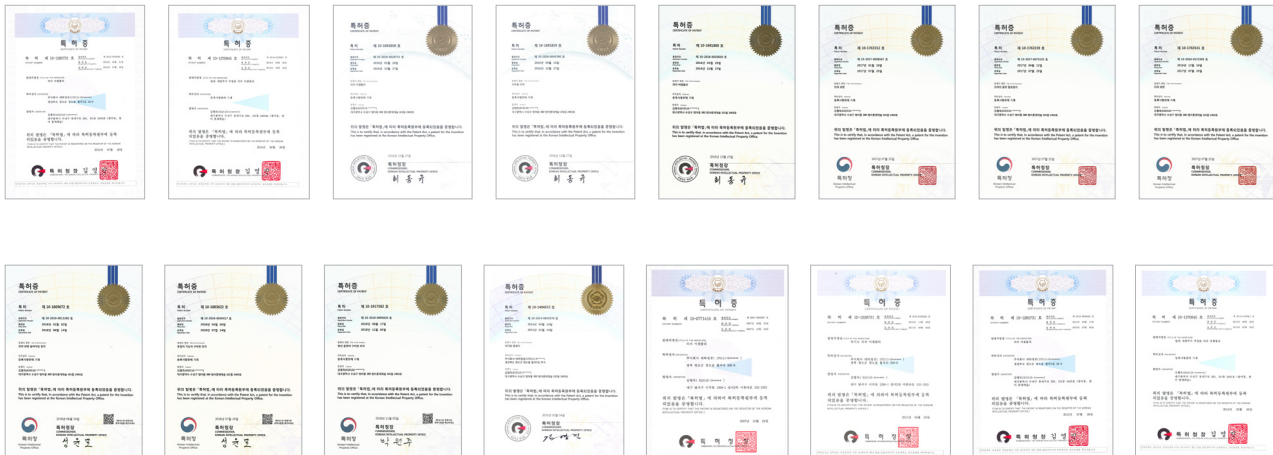

실용신안



상표, 서비스



디자인



ISO9001, 14001



경기도 유망중소기업



벤처기업



경영혁신형 중소기업



기술혁신형 중소기업

